

Product P/N  
10073976-X01LF

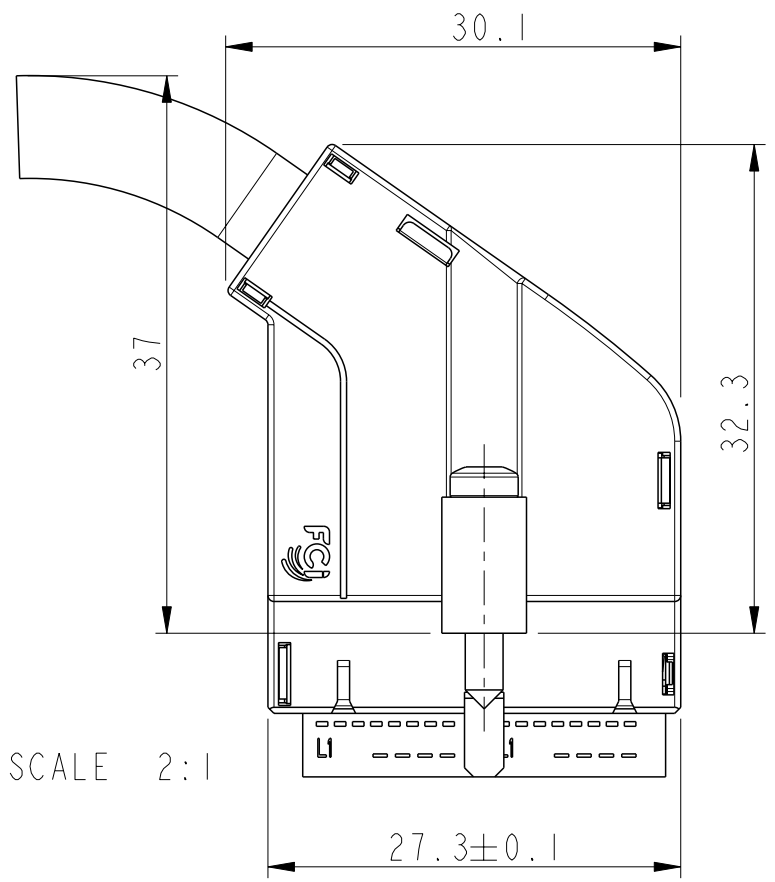

SCALE 2:1

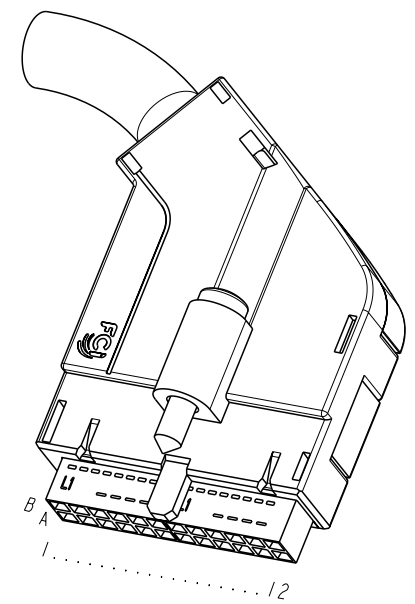
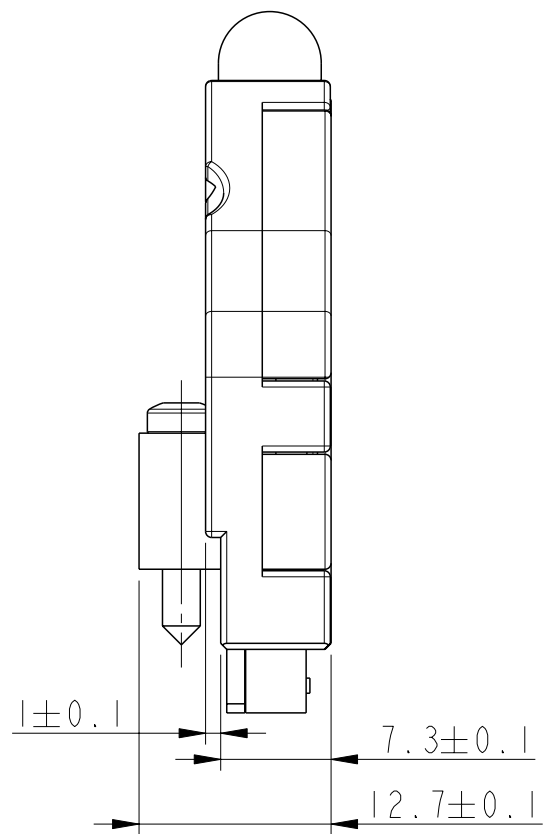

SCALE 3:2

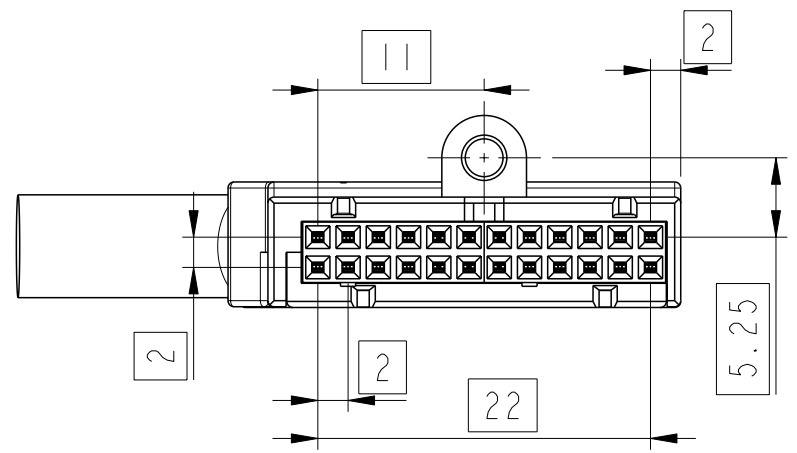

Performance level	
10073976-1XXLF	Telcordia CO.
10073976-0XXLF	Customer Special



www.fciconnect.com		surface ISO 1302	tolerance std ISO 406 ISO 1101	projection mm
		TOLERANCES UNLESS OTHERWISE SPECIFIED		mm
Dr	J.Taron	2006/03/29	ANGULAR	size A4
Eng	J.Taron	2006/03/29	LINEAR	Scale 1:1
Chr	P.Legare	2006/05/22	0° ±2°	ECN LS07-0255
Appr	P.Legare	2006/05/22	Product family	Spec ref RELEASED
FCI 2 x 12 POS IDC CABLE CONNECTOR KIT			dwg no 10073976C	Rev. B
catalog no			CUSTOMER	sheet 1 of 2

rev	ecn no	dr	date
A	LS06-0172	JTA	2006/10/31
B	LS07-0255	JTA	2007/11/13



Copyright FCI.

### KIT: 10073976-X01LF



COMPONENTS	QTY	REP
BOTTOM COVER	1	1
TOP COVER + SCREW	1	2
CABLE CLAMP	1	3
CLAMP SCREW	1	4
TERMINAL BLOCK	1	5
TERMINAL BLOCK	1	6
CABLE	-	7

LEAD-FREE PRODUCT:

(See ROHS INFORMATIONS)

Dimension with oval around are critical dimensions including any attached geometrical tolerance. Other features or stand-alone geometrical tolerances being critical have a note "CRITICAL FEATURE" below the item

A symbol  (x: drawing current revision) will be next to any dimension, view or note which has been modified with the current drawing revision

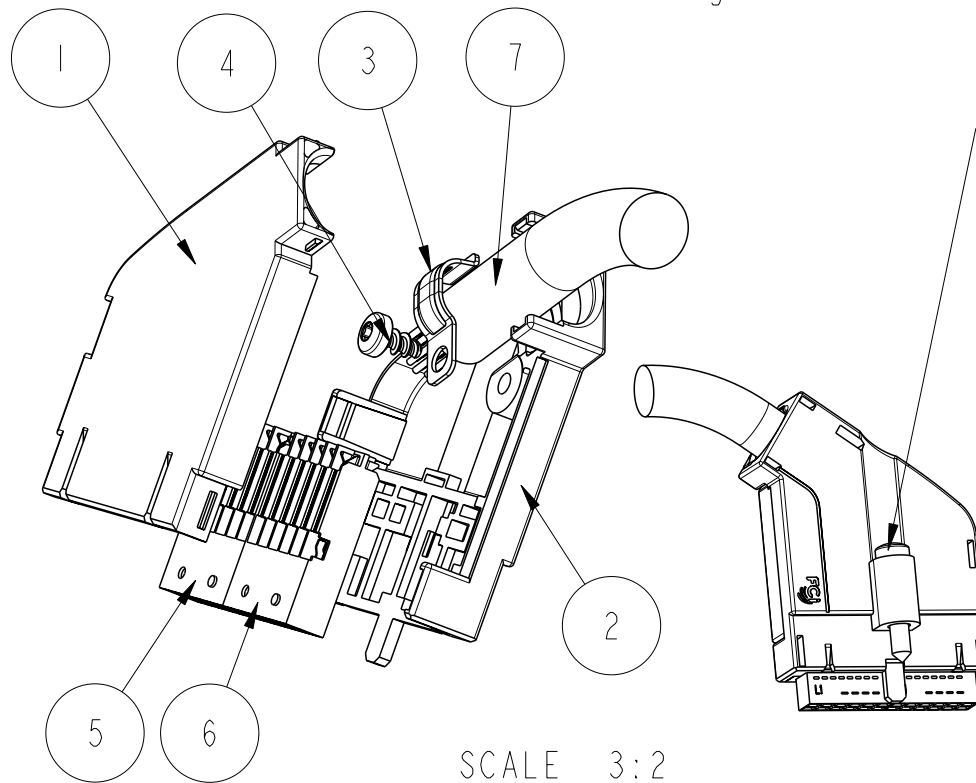

Pre mounted unloosable Torx screw

NOTES: Product specification: GS-12-404  
 Packaging Specification: GS-14-1101  
 Application Specification: GS-20-082

#### ROHS INFORMATIONS:

- This product meets European Union Directives and other country regulations as described in GS-22-008.
- The product is not intended to be exposed to a manufacturing solder process
- Packaging spec: see GS-14-1101.

www.fciconnect.com		surface ISO 1302	tolerance std ISO 406 ISO 1101	projection mm
		TOLERANCES UNLESS OTHERWISE SPECIFIED		
Dr	J. Taron	2006/03/29	ANGULAR	size A4
Eng	J. Taron	2006/03/29	LINEAR	Scale 1:1
Chr	P. Legare	2006/05/22	0° ±2°	ECN LS07-0255
Appr	P. Legare	2006/05/22	Product family	Spec ref RELEASED
			2 x 12 POS IDC	Rev. B
			CABLE CONNECTOR KIT	dwg no 10073976C
			catalog no	CUSTOMER sheet 2 of 2



Copyright FCI.